

HI-SCAN™ 6046si



Feature Highlights

- New X-ray generator with optimized spectrum
- New HiTraX II system platform with extended scope of services
- High resolution image display with doubled resolution
- Up to 37 mm steel penetration
- Wire detectability up to AWG 41

HI-SCAN 6046si is a consequent advancement of HI-SCAN 6040i, with more than 6000 installations worldwide the most successful X-ray inspection system in its class.

HI-SCAN 6046si, despite all similarities, is by far more than a conventional X-ray system with a facelift. Crucial technological innovations concerning X-ray sensor and image processing technologies were part of the R&D process.

HI-SCAN 6046si is equipped with an advanced multi-energy X-ray generator, a new generation of electronics plus a completely novel high resolution detector line.

Due to this optimized technology, the system demonstrates performance rates unachieved before.

HI-SCAN 6046si produces extremely detailed X-ray images, which impress by a more than doubled number of real, physical pixels. The drastically enhanced image resolution of the scanned objects represents a decisive advantage for image evaluations in security areas.

HI-SCAN 6046si additionally has a higher tunnel opening and therefore can scan objects, whose sizes exceed standard dimensions for hand luggage in the aviation industry.

HI-SCAN 6046si - increased security by advanced technology.

General Specifications

Tunnel dimensions	620 (W) x 460 (H) [mm] • 24.4" (W) x 18.1" (H)
Max. object size	615 (W) x 455 (H) [mm] • 24.2" (W) x 17.9" (H)
Conveyor height ¹⁾	approx. 694 mm [27.3"]
Conveyor speed at mains frequency 50 Hz / 60 Hz	approx. 0.2 / 0.24 [m/s]
Max. conveyor load (evenly distributed) ⁵⁾	160 kg [352 lbs]
Resolution (wire detectability) ²⁾	standard: 40 AWG (0.08 mm) • typical: 41 AWG (0.07 mm)
Penetration (steel) ²⁾	standard: 35 mm • typical: 37 mm
External dose rate	≤ 2 µSv/h (0,2 mrem)
Film safety	Guaranteed even for high speed films up to ISO 1600 (33 DIN)
Duty cycle	100 %, no warm-up procedure required

X-ray Generator

Anode voltage • cooling	160 kV cp • hermetically sealed oil bath
Beam direction	diagonal

Image Generating System

X-ray converter	L-shaped detector line, high resolution
Grey levels stored	4096
Image presentation	B/W, color
Digital video memory	1280 x 1024 / 24 bit
Image evaluation functions	VARI-MAT, O ² , OS, HIGH, HI-SPOT, SEN, XPlore, Opti-Zoom, HDA, electronic zoom: stepless enlargement up to 64-times
Monitor	Flat Panel LCD Monitor

Additional Features

Features	fading-in of date/time, luggage counter, user id-number, luggage marking system (acoustic), display of operating mode, REVIEW-feature (to recall previously visible image areas), zoom overview, free programmable keys, USB 2.0 interface, stepless zoom, IMS (Image Store System - stores up to 100,000 images)
Options	X-ACT, HI-TIP, Random ReCheck

Installation Data

X-ray leakage	meets all applicable laws and regulations with respect to X-ray emitting devices.
CE-labelling	in compliance with directives 2006/42/EC, 2014/35/EU, 2014/30/EU
Sound pressure level	< 70 dB(A)
Operating-/ storage temperature	0° - 40°C / -20°C - +60°C
Humidity	5% - 95% (non-condensing)
Power supply ³⁾	standard: 230 VAC or 120 VAC +10% / -15% • 50 Hz / 60 Hz ± 3 Hz
Power consumption	approx. 0.8 kVA
Protection class system/ keyboard	IP 20 / IP 43
Dimensions • Weight ⁴⁾	2004 (L) x 850 (W) x 1290 (H) [mm] • approx. 400 kg 78.9" (L) x 33.5" (W) x 50.7" (H) • approx. 881.9 lbs
Mechanical construction	steel construction with steel panels, mounted on rollers standard color(s): RAL 7016 (dark grey) / B11-W1 (blue)

¹⁾ approx. values (adjustable)

²⁾ proprietary quality management test piece: steel step wedge, CU wires, belt speed 0.2 m/s

³⁾ different values optional

⁴⁾ without control desk, keyboard, monitor(s) etc.

⁵⁾ measured at ambient temperature of 20°C and nominal voltage

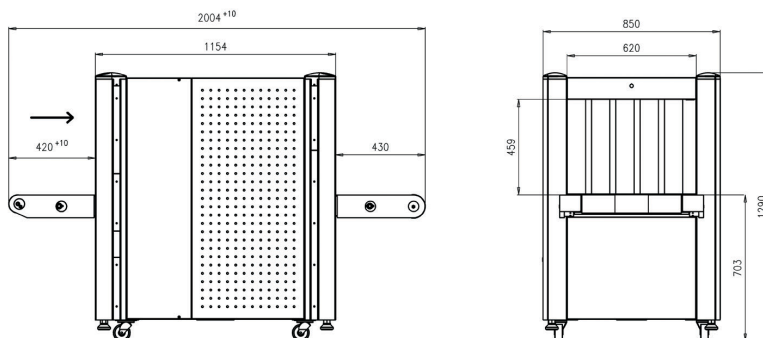

For product information, sales or service, please go to www.smithsdetection.com/locations

Smiths Detection Germany GmbH, Im Herzen 4, 65205 Wiesbaden, Germany
Modifications reserved. 95588620 24/08/2021 © Smiths Detection Group Ltd. - In some cases, the figures contain options
HI-SCAN is a trademark of Smiths Detection Group Ltd.